

FIJI ELECTRICITY AUTHORITY

MR 209/2017

**UPGRADE OF THE CONTROLS AND SWITCHGEARS FOR
WAINIQUEU HYDRO POWER STATION - SAVUSAVU**

**Redesign, Supply, Installation and Commission New Control and
Switchgear System for Wainiqueu Hydro Power Station**

FIJI ELECTRICITY AUTHORITY	PROJECT MANAGER: Eparama Tawake
PRIVATE BAG	PREPARED BY: Atalifo Anise
SUVA	REVIEWED BY: EPARAMA TAWAKE
FIJI	APPROVED FOR ISSUE BY: EPARAMA TAWAKE
Tel 679 - 3313333	
FAX – 679 - 3311882	

SECTION A

INVITATION TO TENDER

The Fiji Electricity Authority ("the Employer") invites sealed bids from eligible bidders for the upgrade of the Controls and Switchgears for Wainiqueu Hydro Power Station, Savusavu.

Bidders may obtain further information and acquire the bidding documents from:

Tuvitu Delairewa
General Manager Commercial
2 Marlow Street,
Suva, FIJI.
Phone: 679 3224 185
Facsimile: 679 331 1882
Email: TuvituD@fea.com.fj

All bids must be delivered to Tuvitu Delairewa, General Manager Corporate Services, 2 Marlow Street, Suva, Fiji, Phone: (679) 3224 185, Facsimile: (679) 331 1882 Email: TuvituD@fea.com.fj at or before **4.00 pm Wednesday 6th September, 2016.**

SECTION B: Instruction to Tender Bidders

- B1.1 This Invitation for Tenders is open to all tenderers. The successful tenderer shall complete the supply of goods by the intended completion date specified in the tender document.
- B1.2 Tenderers shall not be under a declaration of ineligibility for corrupt and fraudulent practices.

B2. Cost of Tendering

- B2.1 The Tenderer shall bear all costs associated with the preparation and submission of its tender, and Fiji Electricity Authority, will in no case be responsible or liable for those costs, regardless of the conduct or outcome of the tendering process.

The Tender Document

B3 Contents

- B3.1 The tender document comprises the document listed below and addenda issued in accordance with Clause B5 of the Instructions to Tenderers
- a) Invitation for Tenders
 - b) Instructions to Tenderers
 - c) General Conditions of Contract
 - d) Special Conditions of Contract
 - e) Technical Specifications and Price Schedules
 - f) Tender Form
- B3.2 The Tenderer is expected to examine all instructions, forms, terms, and specifications in the tender document. Failure to furnish all information required by the tender document or to submit a tender not substantially responsive to the tender document in every respect will be at the tenderer's risk and may result in the rejection of its tender.

B4. Clarification of Tender Document

- B4.1 A prospective tenderer requiring any clarification of the tender document may notify:

Mr. Tuvitu Delairewa in writing:
General Manager Corporate Services
Fiji Electricity Authority
2 Marlow Street, Suva Fiji
Phone: 679 322 4185
Email: TDelairewa@fea.com.fj

B5. Amendment of Tender Document

- B5.1 At any time prior to the deadline for submission of tenders, Fiji Electricity Authority, for any reason whether at its own initiative or in response to a clarification requested by a prospective tender, may modify the tender document by amendment.
- B5.2 All prospective tenderers that have received the tender document will be notified of the amendment in writing and will be binding on them.
- B5.3 In order to allow prospective tenders reasonable time to take the amendment into account in preparing their tenders, Fiji Electricity Authority at its direction, may extend the deadline for the submission of tenders.

Preparation of Tenders

B6. Language of Tender

- B6.1 The tender prepared by the tenders, as well all correspondence and document relating to the tender exchanged by the tender and Fiji Electricity Authority shall be written in English.

B7. Document Comprising the Tender

- B7.1 The tender prepared by the tenderer shall comprise the following components:
 - a) A tender Form and Price Schedule completed in accordance with Clauses B8, B9 and B10 below; refer to Attachment 1 for Price Schedule template

B8. Tender Form

- B8.1 The tenderer shall complete the Tender Form and the Price Schedule furnished in the tender document, indicating the goods to be supplied, a brief description of the goods quantity and prices.

B9. Tender Prices

- B9.1 The tenders shall indicate on the appropriate Price Schedules the unit prices and the total tender price of the goods it produces to supply under the contract
- B9.2 For local suppliers, prices indicated on the Price Schedule shall be delivered to Fiji Electricity Authority,
- B9.3 Prices quoted by the tenderer shall be fixed during the tender's performance of the contract and not subject to variation on any account. A tender submitted with an adjustable price quotation will be treated as non-responsive and will be rejected, pursuant to Clause B21.

B10. Tender Currencies

- B10.1 Prices shall be quoted in USD, AUD, NZD or Fijian Dollars or in other freely convertible currency.

B11. Good's Eligibility and Conformity to Tender Documents

- B11.1 The tenders shall furnish, as part of its tender, documents establishing the eligibility and conformity to the tender documents of all goods, which the tenderer proposes to supply under the contract.
- B11.2 The documentary evidence of conformity of the goods to the tender documents may be in the form of literature, drawings and data, and shall consist of:
 - a) A detailed description of the essential technical and performance characteristics of goods;

- b) A clause-by-clause commentary on Fiji Electricity Authority's Technical Specifications demonstrating substantial responsiveness of the goods to those specifications, or a statement of deviation and exceptions of the Technical Specifications.

B12. Validity of Tenders

- B 12.1 Tenders shall remain valid for 60 days. A tender valid sorter period shall be considered as non-responsiveness
- B 12.2 In exceptional circumstances, Fiji Electricity Authority may solicit the tenderer's consent to an extension of the period of validity. The request and the response thereto shall be made in writing (email). A tenderer granting to be request will not be required nor permitted to modify the tender

B13. Format and Signing of Tender

- B 13.1 The tenderer shall prepare an original and two copies of the tender, clearly marking "**ORIGINAL TENDER**" and "**COPY OF TENDER**," as appropriate. In the event of any discrepancy between them, the original shall govern.
- B 13.2 The original and copy of the tender shall be typed or written in indelible ink and shall be signed by the tenderer or a person or persons duly authorized to bind the tenderer to the contract.
- B 13.3 The tender shall have no interlineations, erasures, or overwriting except as necessary to correct errors made by the tenderer, in which case such corrections shall be initialed by the person or persons signing the tender.

Submission of Tenders

B14. Sealing and Marking of Tenders

Bidders are to submit two (2) hard copies of tenders in sealed envelope into the tender box located at the Supply Chain Office at the FEA Head Office in Suva and also electronic copy shall be uploaded on the evalua website.

- B 14.1 The tenderer shall seal the original and copies of the tender in separate envelopes, duly marking the envelopes as "**ORIGINAL**" and "**COPY.**" The envelopes shall then be sealed in an outer envelope.
- B 14.2 The inner and outer envelopes shall:
- (a) Be addressed to:
The Secretary Tender Committee
2 Marlow Street
Suva
FIJI.
Phone: 679 3224 185
Facsimile: 679 331 1882
Email: TDelairewa@fea.com.fj
 - (b) Bear the following Identification, "**TENDER No. MR 209/2017 - "UPGRADE OF THE WAINIQUEU HYDRO POWER STATION - SAVUSAVU"**
- B 14.3 The inner envelopes shall also indicate the name and address of the tenderer to enable the tender to be returned unopened in case it is declared "late".

B 14.4 If the outer envelope is not sealed and marked as required by Clause B15.2, Fiji Electricity Authority will assume no responsibility for the tender's misplacement or premature opening.

B 14.5 All tender documents can be also sent to the Secretary Tender Committee through the website:

www.evalua.com.au/fea

B15. Deadline for Submission of Tenders

B 15.1 Tenders must be received by Fiji Electricity Authority on the **Wednesday 6th September, 2017** no later than 4.00pm.

B 15.1.1. A site visit is compulsory for all Bidders and is scheduled for **Wednesday 23th August 2017**. All interested Bidders shall meet at Savusavu Power Station at 9am on same morning before FEA directs and travel with the Bidders to Wainiqueu Hydro Power Station. All Bidders are expected to provide their own transport.

B 15.1.2. All tenders will be opened at the Head Office of the Fiji Electricity Authority, 2 Marlow Street, Suva at 1400 hours 07/09/2017 by the Secretary, Fiji Electricity Authority Tender Committee in the presence of three other responsible officers.

B 15.2 Fiji Electricity Authority may, at its discretion, extend this dead line for the submission of tenders by amending the tender document in accordance with clause B5, in which case all rights and obligations of Fiji Electricity Authority and tenderers previously subject in the deadline will thereafter be subject to the deadline as extended.

Courier charges for delivery of Tender Document must be paid by the bidders and where applicable, all other cost such as Duty, VAT and Customs clearance associated with the delivery of Tender Document must also be paid by the bidders, delivered to FEA Delivered Duty Paid (DDP).

B16. Modification and Withdrawal of Tenders

B 16.1 The tenderer may modify or withdraw its tender after the tender's submission, provided that written notice of the modification, including substitution or withdrawal of the tenders, is received by Fiji Electricity Authority prior to the deadline prescribed for submission of tenders.

B 16.2 The tenderer's modification or withdrawal notice shall be prepared, sealed, marked, and dispatched in accordance with the provisions of Clause B15. A withdrawal notice may also be e-mailed, but followed by a signed confirmation copy, postmarked no later than the deadline for submission of tenders.

B 16.3 No tender will be modified after the deadline for submission of tenders.

B 16.4 No tender will be withdrawn in the interval between the deadline for submission of tenders and the expiration of the period of tender validity specified by the tenderer on the Tender Form.

Opening and Evaluation of Tenders

B17. Opening of Tenders

B 17.1 Fiji Electricity Authority will open all tenders with the presence of Fiji Electricity Authority nominated Tender Committee, without presence of the bidder's representative.

B17.2. Each member of the tender committee will initial tender pages of the tender documents and record total price tendered before submitting to the Tender Evaluation Committee for further evaluation.

B18. Clarification of Tenders

B 18.1 To assist in the examination, evaluation and comparison of tenders Fiji Electricity Authority at its discretion,

ask the tenderer for a clarification of its tender. The request for clarification and the response shall be in writing, and no change in the prices or substance of the tender shall be sought, offered, or permitted. Any effort by the tenderer to influence Fiji Electricity Authority in its decision on tender evaluation tender comparison or contract award may result in the rejection of the tenderer's tender.

B 19 Preliminary Examination

- B 19.1 Fiji Electricity Authority will examine the tenders to determine whether they are complete, whether any computational errors have been made, whether the documents have been properly signed, and whether the tenders are generally in order.
- B 19.2 Arithmetical errors will be rectified on the following basis. If there is a discrepancy between the unit price and the total price that is obtained by multiplying the unit price and quantity, the unit price shall prevail, and the total price shall be corrected. If the tenderer does not accept the correction of the errors, its tender will be rejected. If there is a discrepancy between words and figures, the amount in words will prevail.
- B 19.3 Fiji Electricity Authority may waive any minor informality or non-conformity or irregularity in a tender which does not constitute a material deviation, provided such waiver does not prejudice or affect the relative ranking of any tenderer.
- B 19.4 Prior to the detailed evaluation, pursuant to Clause B21, Fiji Electricity Authority will determine the substantial responsiveness of each tender to the tender document. For purposes of these paragraphs, a substantially responsive tender is one, which conforms to all the terms and conditions of the tender document without material deviation. Fiji Electricity Authority's determination of a tender's responsiveness is to be based on the contents of the tender itself without recourse to extrinsic evidence.
- B 19.5 If a tender is not substantially responsive; it will be rejected by Fiji Electricity Authority and may not subsequently be made responsive by the tenderer by correction of the nonconformity.

B20. Evaluating and Comparison of Tenders

- B 20.1 Fiji Electricity Authority will evaluate and compare the tenders, which have been determined to be substantially responsive, pursuant to clause B18.
- B 20.2 Fiji Electricity Authority's evaluation of a tender will exclude and not take into account any allowance for the price adjustment during the period of execution of the contract, if provided in the tender.
- B 20.3 Fiji Electricity Authority's evaluation of a tender will take into account, in addition to the tender price and the price of incidental services, the following factors:
- a) Compliance to Instruction to Tenderers pursuant to Clause B1.3;
 - b) Compliance to the tender requirements pursuant to Clauses B11, B12 and B13;
 - c) Compliance to the technical specifications;
 - d) Tender validity of not less than 60 days;
 - f) Delivery period offered in the tender. The delivery period should not exceed 4 weeks (one month) after the date of signing the Contract;
 - g) Documentary proof of successful delivery of similar assignment deviation in payment schedule from that specified in the Special Conditions of Contract
 - h) Documentary proof of successful delivery of similar assignment.

B21. Contacting Fiji Electricity Authority

- B 21.1 Subject to Clause B18, no tenderer shall contact Fiji Electricity Authority on any matter relating to its tender, from the time of the tender opening to the time the contract is awarded.
- B 21.2 Any effort by a tenderer to influence Fiji Electricity Authority in its decisions on tender evaluation, tender comparison, or contract award may result in the rejection of the tenderer's bid.

Award of Contract

B22. Award Criteria

B 22.1 Subject to Clauses B9, B21 and B25 Fiji Electricity Authority will award the contract to the successful tenderer(s) whose tender has been determined to be substantially responsive and has been determined to be the lowest **evaluated** tender.

B23. Fiji Electricity Authority's Right to accept or Reject any or All Tenders

B 23.1 Fiji Electricity reserves the right to accept or reject any tender, and to annul the tendering process and reject all tenders at any time prior to contract award, without thereby incurring any liability to the affected tenderer or tenderers or any obligation to inform the affected tenderer or tenderers of the grounds for its action.

B24. Notification of Award

B 24.1 Prior to the expiration of the period of tender validity, Fiji Electricity Authority will notify the successful tenderer in writing that its tender has been accepted.

B25. Signing of Contract

B 25.1 At the same time as Fiji Electricity Authority notifies the successful tenderer that its tender has been accepted, Fiji Electricity Authority will send the tenderer the Contract Form provided in the tender document, incorporating all agreements between the parties.

B 25.2 Within five (5) working days of receipt of the Contract Form, the successful tenderer shall sign and date the contract and return it to Fiji Electricity Authority

B26. Corrupt or Fraudulent Practices

B 26.1 Fiji Electricity Authority requires that tenderers observe the highest standard of ethics during the Procurement process and execution of contracts. In pursuance of this policy, Fiji Electricity Authority:-

- a) defines, for the purposes of this provision, the terms set forth below as follows:
 - I. "*corrupt practice*" means the offering, giving, receiving or soliciting of anything of value to influence the action of a public official in the procurement process or in contract execution; and
 - II. "*fraudulent practice*" means a misrepresentation of facts in order to influence a procurement process or the execution of a contract to the detriment of Fiji Electricity Authority, and includes collusive practice among tenderers (prior to or after tender submission) designed to establish tender prices at artificial noncompetitive levels and to deprive Fiji Electricity Authority of the benefits of free and open competition;
- b) Will reject a proposal for award if it determines that the tenderer recommended for award has engaged in corrupt or fraudulent practices in competing for the contract in question
- c) Will declare a firm ineligible, either indefinitely or for a stated period of time, to be awarded any contract if it at any time determines that the firm has engaged in corrupt or fraudulent practices in competing for, or in executing, a contract.

B 26.2 Furthermore, tenderers shall be aware of the provision stated in the General Conditions of Contract.

SECTION C: General Conditions of Contract

General Condition of this Contract will adopt FIDIC

SECTION D: Special Condition of Contract

D1. Interpretation

In these Conditions, unless the context otherwise requires:

Accepted Contract Price: means the amount agreed as per Clause B5.1 as the total price payable by FEA to the Supplier/Contractor according to this Agreement.

Agreement means the agreement for the required works of which these Conditions; and the Schedules form part of this agreement.

Conditions mean these General Conditions for the required works according to this Agreement.

Confidential Information means any technical, scientific, commercial, financial or other information of, about or in any way related to the Supplier, including any information designated by the Supplier as confidential, which is disclosed, made available, communicated or delivered to FEA, but excludes information:

- (a) which is in or which subsequently enters the public domain other than as a result of a breach of these Conditions; or
- (b) which the Supplier/Contractor can demonstrate was in its possession prior to the date of this Agreement; or
- (c) which the Supplier/Contractor can demonstrate was independently developed by it; or
- (d) which is lawfully obtained by the Supplier/Contractor from another person entitled to disclose such information.

Delivery Point means Butoni Windfarm.

FEA means the Fiji Electricity Authority or its Authorized Representative advised in writing.

Intellectual Property Rights includes all present and future copyright, all proprietary rights in relation to inventions (including patents), registered and unregistered trademarks, confidential information (including trade secrets and know how), registered designs, circuit layouts, and all other proprietary rights resulting from intellectual activity in the industrial, scientific, literary or artistic fields.

Laws mean the law in force in Fiji, including common law and legislation.

Local Authority means Fiji Revenue and Customs Authority and any other regulatory body in Fiji.

Equipment /Service means the required equipment or service which will be supplied by the Supplier/Contractor in accordance with Schedule

Purchase Order means purchase order or acceptance from the Supplier/Contractor for the supply of the Equipment/Service and required works which incorporates these Conditions.

Specification means the technical specifications to which the required works must comply, as set out in Schedule 1 in this Agreement.

Supplier/Contractor means the Supplier or Contractor and its representatives who is providing the required Equipment or Service.

Time for Delivery means the date and, where relevant, the time specified in the Purchase Order (or such other date or time as may be agreed in writing) by or on which delivery of the equipment/service and required works must be effected by the Supplier.

D2 Commencement Date

- D2.1 This Agreement shall come into effect upon signing by both parties.
- D2.2 This Agreement may be executed in several counterparts (including facsimile copies), all of which when signed and taken together constitute a single agreement between the parties
- D2.3 After execution of this Agreement, FEA shall issue an official Purchase Order to enable the Contractor to initialize the required works and both FEA and the Contractor shall proceed with the performance of its respective obligations hereunder.

D3 Supply, Packaging and Delivery of Equipment/Service

- D3.1 The Conditions of Supply and Delivery of the of required equipment /service are as follows;
- (a) The Supplier must supply the Equipment/Service to FEA in accordance with Schedule 1 and with this Agreement.
 - (b) The Supplier shall ensure that the equipment supplied will meet the design, technical guarantee and performance criteria as required by FEA as per the Work Scope Specification of this Agreement.
 - (d) The Supplier will deliver the Equipment/Service to the Delivery Point that is Wailoa Power Station..
 - (e) Nothing in this Clause shall in any way release the Supplier from any Warranty or other obligation under this Agreement in case of deterioration or damage until such time the required equipment/service are successfully delivered to FEA.

D4 Transfer of Title and Ownership of the Equipment/Service

The required equipment/Service shall to the extent consistent with the governing Laws, become the property of FEA:

- (i) when it is delivered to the Delivery Point; and
- (ii) when the Supplier/Contractor is fully paid for the value of the equipment under Clause D5.1 and Schedule 1.

D5 Price, Invoicing and Payment

- D5.1 FEA will pay the sums on the Payment Schedule which will be agreed by both the FEA and Supplier/Contractor or in the offer letter upon completion and successfully commissioning of scoped works by both parties.
- D5.2 The Supplier/Contractor will submit to FEA a detailed original invoice according to paragraph (D5.1) in order for FEA to process payment, together with such other information as FEA may reasonably require. The original invoice must be sent to FEA's Unit Leader Procurement Accounting, Head Office of FEA.
- D5.3 All original invoices issued pursuant to this Agreement shall be expressed in the Fijian Currency or Foreign Currency agreed by both parties and will be issued using the Supplier's/Contractor's letterhead.

- D5.4 FEA will pay the Supplier payment as stipulated on the agreed Payment Schedule of this Contract, upon the written approval from FEA's Authorized Representative that the required Equipment/Service are in good and satisfying condition.
- D5.5 Unless specified otherwise in this Agreement, FEA will pay the amounts specified in the original invoice as being payable within thirty [30] days from date of receipt of such invoice.
- D5.6 FEA shall not be responsible to pay invoices issued by the Contractor if such original invoices are not in conformance with the above stated requirements.
- D5.7 Any Advance Payment required by the Contractor shall require a Bank Guarantee in accordance to the following FEA Conditions;
- a) Amount of bank guarantee must be equal to the advance payment on the contract.
 - b) The Bank Guarantee is to be to a designated bank in Fiji accepted by FEA or
 - c) The Supplier's Banker must directly liaise with the banker of FEA.
 - d) Validity of Bank guarantee as per the contract terms & conditions to be provided to FEA.
 - e) Bank guarantee should be irrevocable & non- negotiable until the expiry date and satisfactory delivery of goods & services.
 - f) The supplier's banker shall meet & satisfy the terms and conditions of the designated banker of FEA to ensure that Bank guarantee is issued.
- D5.8 A 10% Retention on every payment will executed on all payment stipulated on the agreed Payment Schedule. This 10% Retention will be released 20days after the Warranty Period of the Works expires and after notification from the Supplier/Contractor for the release of fund.

D6 Warranty and Performance Warranty

- D6.1 The Contractor will provide a 12 (twelve) months warranty for the Equipment/Service supplied from the date of the Equipment been fully Commissioned and acceptance signed off by the FEA representative. The Supplier warrants that the Equipment/Service supplied under this Agreement shall operate within specified guaranteed performance levels during the 12 (twelve) months Warranty period. .
- D6.2 The Equipment/Service supplied shall meet the requirements and standards detailed in FEA's Specification and as per the Tender proposal and the Supplier warrants that the Equipment/Service will remain free from defects for the warranty period from the time it is used for operation.
- D6.3 FEA shall promptly notify the Supplier in writing of any claims arising under this warranty, upon receipt of such notice, the Supplier shall with all reasonable speed, correct, repair or replace the defective Equipment /Service without any cost to FEA.

D7 Indemnity and Limitation of Liability

- D7.1 The Supplier/Contractor shall indemnify FEA and each of its employees and agents against any loss, damage, claim, action or expense (including legal expense) which any of them may suffer as a direct result of failure to deliver the Equipment/Service accordance with this Agreement or any other breach of this Agreement provided FEA gives prior notice of personal and/or agent involved.

D7.2 The total liability of the Supplier/Contractor to FEA under this Contract shall be the Accepted Contract Amount.

D8.0 Delivery and Factory Acceptance Test

D8.1 The Contractor is to submit the Manufacture schedule within 20 days of the acceptance of his tender for approval, a programme showing the order in which he proposes to carry out the works, including design, manufacture and delivery of all required equipment /switchgears, that is to be completed within 8 months.

D8.2 The Authority's Engineer or his representative shall have the right to inspect and/or to witness test the Transformers at the factory or place of manufacture, for their conformity to the Contract Specifications. The Authority shall notify the Contractor in writing of the identity of its Engineer(s) or representative(s) retained for these purposes. The contractor shall provide the authority with a detailed program for the inspections and/or witness tests and notice of at least 144 hours of notice when the materials, equipment, system is ready for inspection & testing. Nothing in this clause shall in any way release the Contractor from any warranty or other obligations under this Contract in delivering a fully functional plant as specified elsewhere in this document or the contractors' design and specifications.

D9 Liquidated Damages for Delay Delivery

D9.1 If the Supplier/Contractor fails to comply with **Clause 8.0** the Supplier/Contractor shall pay delay damages to FEA for this default.

D9.2 The delay damages shall be the sum stated as follows:

(i) FJ\$200 [Five Hundred Dollars] per day for the first seven [7] days of Delay; and

(ii) FJ\$500 [Five Hundred Dollars] per day for each day after the lapse of the first seven [7] days for the delay.

D9.3 The parties agree that the liquidated delay damages sum represents a reasonable pre-estimate of direct loss that FEA would suffer in the event of failure by the Supplier/Contractor to comply with Clause 8.0.

D10 Insurance

The Supplier/Contractor shall provide for 100% insurance cover for the Equipment/Service supply, transport, including third party liabilities and Suppliers All Risk insurance for the Equipment/Service and any applicable consequential damage insurance due to the Supplier's activity/negligence until the Equipment/Service are delivered.

D11 Sub-contracting

- D11.1 The Supplier/Contractor must not sub-contract to any third person/party any of its obligations in relation to the supply of the Equipment/Service without the prior written consent of FEA (which may be given or withheld in its absolute discretion).
- D11.2 The Supplier/Contractor will not, as a result of any sub-contracting arrangement, be relieved from the performance of any of its obligations under this Agreement and will be liable for all acts and omissions of a sub-Supplier as though the actions were that of the Supplier itself.

D12 Compliance with Law

The Contractor must, in the supply of the Equipment/Service and the required works, comply with all Laws of Fiji and with the lawful requirements or policy of FEA.

D13 Termination

D13.1 Events of Termination

- (a) It is an event of termination if:
- (i) there is a failure by either party (defaulting party) to comply with any undertaking or obligation in this Agreement and the defaulting party does not remedy the failure within fifteen [15] Business Days, or a longer period as determined by the party ("non-defaulting party") after the defaulting party receives written notice from non-defaulting party specifying the failure; or
 - (ii) either party suspends payment of its debts generally or is, or becomes unable to pay its debts when they become due and owing; or
 - (iii) either party ceases or threatens to cease to carry on its business or operations; or
 - (iv) either party assigns or purports to assign this Agreement otherwise than in accordance with the terms of this Agreement; or
 - (v) either party sells or transfers a majority or controlling shareholding interest in itself; or
 - (vi) a receiver, and manager, administrator, trustee or similar official is appointed over either party's assets or undertakings an application or order is made for winding up steps to be taken or passes a resolution for the winding up or dissolution of either party.
 - (vii) Either party will give the other two [2] weeks' written notice (Notice) of an Event of Termination

D13.2 Effect of an event of Termination

If the defaulting party fails to remedy or rectify any Event of Termination on or before the expiry of the two weeks from the date of the Notice, the non-defaulting party may, without prejudice to its other rights and remedies, terminate this Agreement immediately by giving written notice to the other.

D13.3 Continuing Terms

When this Agreement expires or is terminated under Clause 13 or otherwise:

- (a) all order placed by FEA with the Supplier/Contractor for the Equipment/Service is automatically cancelled, unless otherwise advised by FEA and agreed to in writing by the Contractor;
- (b) FEA must within ten [20] Business Days after expiry or termination, pay the Supplier/Contractor all amounts owing by it to the Supplier/Contractor that are due at that time; and

- (c) The Contractor must, within ten [20] Business Days after expiry or termination, pay FEA all amounts owing by it to FEA.

D14 GOVERNING Law and Jurisdiction

This Agreement is governed by and is to be construed in accordance with the laws applicable in Fiji. Each party irrevocably and unconditionally submits to the exclusive jurisdiction of the Courts of Fiji and any Courts which has jurisdiction to hear appeals from any of those Courts and waives any right to object to any proceedings being brought in those Courts.

D15 Dispute Resolution

The following procedure will apply if a dispute under this Agreement arises:

- (a) If a dispute arises, the party claiming that a dispute has arisen will give written notice to the other party indicating the nature of the dispute. Upon receipt of the notice, the parties must appoint at least one senior representative, who must, within 7 days from the date of receipt of the notice of the dispute, meet with each other, and attempt to resolve the dispute.
- (b) If the parties fail to resolve the dispute within 14 days from the date of meeting, the dispute will be referred to the respective parties' Managing Director/ Chief Executive Officer, or their nominees, who must then meet and attempt to resolve the dispute within 7 days.
- (b) If the parties fail to resolve the dispute within the further 7 day period, the parties must mutually agree to appoint an Independent Arbitrator to determine the dispute.
- (c) The decision of the Arbitrator, in the absence of manifest error, will be conclusive and binding. Such reference shall be deemed to be arbitration pursuant to the Arbitration Act [Cap. 38] of Fiji or any statutory modification of that Act.
- (d) All cost of the Arbitrator together with any expert report will be borne equally between the parties.

D16 Force Majeure

Notwithstanding anything to the contrary herein contained, should either of the parties hereto be prevented from fulfilling in whole or in part its obligations in terms of this Agreement, whether such prevention arises from Force Majeure, Act of God, war, civil commotion, strikes, lockouts, revolution, fires, explosions, floods, political disturbances, acts of any Government or local authority, breakdown of plant or machinery, or any other cause whatsoever over which the party has no reasonable control over, such party shall be exempted from liability to the extent and for the period it shall hereby have been prevented from fulfilling its obligations hereunder and shall immediately notify the other to that effect and confirm this in writing giving a full and complete explanation of the circumstances responsible for such failure or occurrence as well as the estimated duration thereof and if requested the action(s) that such party is taking or proposes to take to remove the said circumstances with the least delay possible as well as the actions(s) to be taken to prevent future recurrences.

Either Party claiming relief for a Force Majeure Event shall:

- a) Give written notice of the occurrence of the Force Majeure Event to the other Party; and
- b) Do all things reasonably required to mitigate the effect of the Force Majeure Event.

After the Force Majeure Event, the Party claiming relief for a Force Majeure Event will expedite in performing its obligation or condition expediently under this Agreement

TECHNICAL SPECIFICATIONS

SYSTEM DESIGN & UPGRADE OF THE WAINIQUEU HYDRO

POWER STATION

1.0 BACKGROUND

Wainiqueu Power Station is located close to Savusavu Town on the second biggest island in Fiji. This Mini Hydro Power Station was built through a Chinese aid and construction was done by a Chinese Contractor from China and was commissioned in 1992.

This Mini Hydro Power Station is a Run Off the River System where water is diverted by the use of two Weir catchment and water piped to a Head Pond Tank before it is piped again to the Hydro Power Station.

There are two 400kW Generator turbines installed which are fed from a single surface laid penstock with a Head of about 88.9mtrs. The Head Pond is a concrete structure tank.

All the equipment installed in this Hydro Power Station is made from China and includes the following;

1. The Francis Turbine
2. Alternator
3. Excitation
4. Controls
5. 11kV Switchgears
6. Transformers

Tender Requirement

This Tender requires the Bidders to redesign, manufacture, supply, install and commission the following existing;

1. The 415V layout system
2. The 11kV switchgears
3. Transformers
4. Controls and Protections
5. Governors
6. Excitations
7. DC Supply system

Note:

The Bidders are also required to remove the old panels and relocate the same to a place FEA will assign for this purpose.

2.0 Objective of the Review

The purpose of the upgrade is two (2) fold as noted below;

1. Improve the availability and reliability of this Hydro Power Station
2. Utilise whatever water available as to save cost from reducing generation of power by the use of diesel generators at Savusavu Power Diesel Station.

3.0 Expected Brief Report

The Bidders are to Bid according the two terms of reference below;

- 3.1 Submission of Bids with a Brief Report with Drawings on the new designs.

November 2016

3.2 Bidders may require to do a presentation of the new Design System to FEA before FEA decides on the awarding of the Tender.

4.0 Submission Requirements for this Tender

For this assignment submissions shall include the following as a minimum

- 4.1 A covering letter including the complete name and address of the firm(s) performing the project, the principle firm including the name and title of the person principally responsible for the project.
- 4.2 A detailed report of the existing system and equipment
- 4.3 A detailed redesign report with drawings
- 4.4 A detailed methodology including a program for the works and any site visit required and timing of same. Comments on the scope of works can be included to add value to the submission.
- 4.5 A site visit is compulsory for all Bidders and is scheduled for **Wednesday 23rd August, 2017**. All interested Bidders shall meet at Savusavu Power Station at 9am on same morning before FEA directs and travel with the Bidders to Wainiqueu Mini Hydro Power Station. All Bidders are expected to provide their own transport.
- 4.6 State a lump sum fee for the delivery of the entire works including any disbursements. The cost breakdown should also clearly include allocations to the three (3) expected outcomes of the project.
- 4.7 Bidders are to familiarize themselves with local Fijian Taxation requirements and clearly identify relevant local taxes included in their fees.
- 4.8 Bidders are to state clearly the currency(s) that is being used in their schedule of fees
- 4.9 Company background and evidence of similar works undertaken by the firm for the last five (5) years including project name, summary of work carried out, contact name and address of clients.
- 4.10 CVs of personnel that will be engaged in the work including sub-consultants
- 4.11 Completed responsibility Matrix

5.0 The New Design

The Tender Bids should be accompanied with a Basic design overview on the proposed new design with associated cost on the listed items to be upgraded.

5.1 Similar Design

Bidders are expected to use the similar type of equipment and control setup used at the Somosomo Hydro Power Station with exception to the HV switchgears which is expected to be indoor type with SEL Protection Relays.

A copy of the Somosomo Hydro setup attached for Bidders reference in their design.

SOMOSOMO POWER STATION

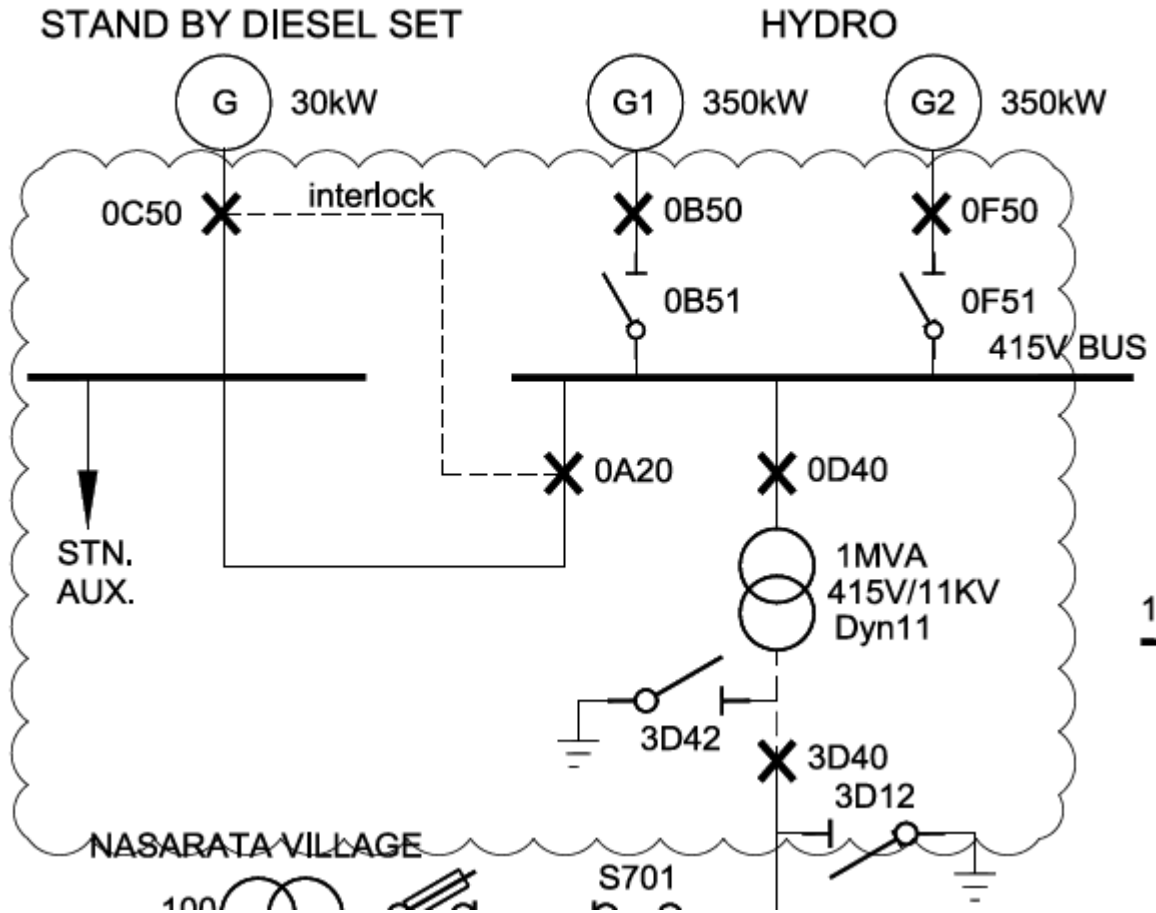

5.2 Complete New Design

Bidders are open to submit their own initiative design but it should be practical and safe to operate.

5.3 Technical

The technical design and specifications of the existing equipment should not be compromised, however technical specs, design, quality and appropriateness of any proposed changes should equal or better than the current system

The recommended changes are to include all relevant electrical & mechanical calculations. Design specifications of the recommended system should be submitted as part of the upgrade report. The appropriate or better electrical protection schemes for the LV & HV system, auxiliary transformers and cables should also be included in the upgrade report. The SEL Protection Relays is compulsory as it is FEA's preferred protection relays.

The PLC and Scada preferred hardware and software are, PLC Schneider and Scada is the Wonderware software.

The excitation upgrade will require the use of the latest Digital system with Local and Remote Control provision. This also applies to the Governor System upgrade

As for Energy meters, Shark 200 v6 meters is FEA's preferred meter and are to be used where it is appropriate in the Bidder's Design. Expected metering point are the two Generator Turbines and the HV Feeder.

5.4 Control and Protection System

The bidder should consider the merit of replacing the existing hard-wire control with other better solutions like Programmable Logic Control system with Scada/HMI. Provision for remote control from our National Control Center at Vuda, Vitilevu are required as per existing equipment.

FEA strongly recommends the SEL Protection Relays for the Protection schemes to be implemented in the new Design.

FEA also recommends the use of Shark 200 v6 Energy Meters or all the energy metering requirements.

5.5 Price

The bidder is expected to submit estimated cost for each section of upgrade and submits with his proposal their respective costs.(Design/Tender/Supervision for each portion of the system).This price will provide FEA an indication of the expected cost of the Project.

November 2016

5.6 Documentation

The Bidder is required to supply three sets of Hard & One Softcopy of Spare parts manuals, Operation & Maintenance manuals, drawings, design & technical information required for site installation, software, and other documentation as per tender.

Three Copies of Software with individual laptops for Operation, Troubleshooting and Maintenance

5.7 Training

The Bidder/Contractor is required to provide Training Material and Training on all upgraded system and equipment.

5.6 Spares

The Bidder/Contractor is required to provide a list of Essential Spares with prices and FEA will raise a separate LPO for this requirement.

6.0 Evaluation Methodology

Submissions will be checked for completeness, firms that fail to submit all information required above may not be considered for award. A 60% weighting shall be given for the firm, personnel background and their submission of Bid and 40% for the sum price

7.0 Scope of Works

The new design should be similar to the new Somosomo Hydro Power Station which was also designed and constructed by the Chinese company Hunan Construction. The following are to be redesigned;

- a) The Controls system to be upgraded to a PLC type (preferred Schneider PLC) which will be remotely linked to FEA Control Centre at Vuda where it will be daily 24/7 monitored controlled from.
- b) A Scada control system (preferred Wonderware system) is recommended for control and monitor of the whole Power Station operation.
- c) The 415V system to be upgraded to a Busbar system where the two Turbine Generators are connected direct to this Bus with their associated SEL Protection Relays. The Power Station auxiliary 415V supply shall be tapped off from this 415V busbar system.
 - i. Withdrawal Type ACB of appropriate ratings shall be used for the 2 Generator Incomers and for the Feeder circuits.
 - ii. Preferred ACB Type is Terasaki Type
 - iii. Preferred HV Switchgear is Hawker Siddeley
- d) There will be a single Step Up three phase Power Transformer YND11 use to transform 415V to 11kV.
- e) The 11KV System shall have one Incomer and one Feeder with SEL Protection relays. Preferred HV Switchgear type is Hawker Siddeley
- f) The Design Upgrade shall have new Station Battery with Charger with Battery rating to last 36hrs. Standby battery bank is also recommended.
- g) The new Design should upgrade the existing Excitation System
- h) The new Design should upgrade the existing Governor system
- i) Upgrades to all auxiliaries motors that uses 380V to 415V
- j) Upgrade to the Dead Weight Vavle and Controls at the Head Pond.



**Fiji Electricity Authority
RFP for Wainiqueu Hydro Power Station Review/Upgrade**

- k) Install inflow/outflow meters and Level meters at the Head Pond and ensure these reading are transmitted down to the Power Station control system for the full utilization of available water.
- l) The PLC program should use the parameters in k) to have the following automatic modes of operation;
 - I. MW setpoint mode- when there is a lot of water available, high inflow
 - II. Water Level Mode – where the PLC maintain the water level when inflow is low
 - III. Start Stop mode – where the inflow is very low and water tanks level reaches high level.

8.0 Pricing Schedule

Bidders are expected to use this format for their Pricing Schedule

Description		\$ Amount Currency: _____
1	Price for the Control System, New Control Panel, PLC and Scada Software and Hardware	
2	Price for the new 415V Board and Control System - New 415V Board	
3	Price for the new HV Switchgear and associated Controls and Protection	
4	Price for the new DC System – Batteries and Charger	
5	Price for the new Excitation System	
6	Price for the new Governor System	
7	Price for the Balance of Equipment required for the upgrade	

November 2016

8	Three sets of Hard & One Softcopy of Spare parts manuals, Operation & Maintenance manuals, drawings, design & technical information required for site installation, software, and other documentation as per tender	
9	Three Copies of Software with individual laptops for Operation, Troubleshooting and Maintenance	
10	Commissioning works Freight, transportation cost, Insurance, Delivered Duty	
11	Training for: <ul style="list-style-type: none"> • Operation & Maintenance of the Generator • Software 	
	TOTAL , Off-Shore cost of Equipment Supply – exclusive of Fiji Import Custom Duty, taxes or other Fiji Government related charges	
12	Local Tax Components	
13		
	TOTAL ,	

Tender Submission - Instruction to bidders

It is mandatory for Bidders to upload a copy of their bid in the **TENDER LINK** Electronic Tender Box no later than **4:00pm, on Wednesday 6th September, 2017**

To register your interest and tender a response, view 'Current Tenders' at:
<https://www.tenderlink.com/fea>

For further information contact The Secretary Tender Committee, by e-mail
TDelairewa@fea.com.fj

In additional, hard copies of the tender, one original and one copy must be deposited in the tender box located at the FEA Head Office, 2 Marlow Street, Suva, Fiji no later than **4:00pm, on Wednesday 6th September, 2017**- Addressed as

Tender – MR 209/2017 Upgrade of the Controls and Switchgears for Wainiqueu Hydro Power Station - Savusavu

**The Secretary Tender Committee
Fiji Electricity Authority
Head Office
Suva
Fiji**

- **Hard copies of the Tender bid will also be accepted after the closing date and time provided a soft copy is uploaded in the e-Tender Box and it is dispatched before the closing date and time.**

Tenders received after **4:00pm** on the closing date of **Wednesday 6th September, 2017**

- Will not be considered.
- Lowest bid will not necessarily be accepted as successful bid
- **It is the responsibility of the bidder to pay courier chargers and all other cost associated with the delivery of the hard copy of the Tender submission including any Duties/Taxes. Hard copies of the Tender submission via Post Box will not be considered.**

November 2016



Fiji Electricity Authority
RFP for Wainiqueu Hydro Power Station Review/Upgrade

November 2016